

PM80-SERIES 60 TO 80 W 1&2 OUT-PUTS



INPUT / OUTPUT

- Optimized input voltage ranges
- Input ranges from 18 to 300 Vd.c.
- Single outputs from 24 to 72 Vd.c.
- Two isolated outputs 24 or 36 Vd.c.
- Reverse input voltage protection

FEATURES

- Wall or DIN-rail mounting
- One unit covers many output voltages
- Output voltage adjustable on frontpanel.

OPERATION

- Operating temperature range -25 to +55 °C (-40 °C on request)
- Fully encapsulated, meets IP20 as standard.
- Convection cooled

OPERATION FEATURES

- Conformally coating; tropical version for environment with high non condensing humidity max 98 % RH.

EMC

- EN IEC 61000-6-3, Emission.
- EN IEC 61000-6-2, Immunity.
- EN IEC 61000-4-4, 4 kV.

SINGLE OUTPUTS

OUTPUT		
Voltage	Current	Power
24 V	2.50 A	60 W
24 V	3.34 A	80 W
36 V	1.68 A	60 W
36 V	2.24 A	80 W
48 V	1.25 A	60 W
48 V	1.67 A	80 W
72 V	0.84 A	60 W
72 V	1.12 A	80 W

INPUT				
18 - 32 V	40 - 60 V	88 - 150 V	175 - 300 V	Connection
PM80 24/24-24				Parallel
	PM80 48/24-24	PM80 110/24-24	PM80 220/24-24	Parallel
PM80 24/36-36				Parallel
	PM80 48/36-36	PM80 110/36-36	PM80 220/36-36	Parallel
PM80 24/24-24				Series
	PM80 48/24-24	PM80 110/24-24	PM80 220/24-24	Series
PM80 24/26-36				Series
	PM80 48/36-36	PM80 110/24-24	PM80 220/24-24	Series

DUAL OUTPUTS

OUTPUT				
Voltage	Current	Voltage	Current	Power
24 V	1.25 A	24 V	1.25 A	60 W
24 V	1.67 A	24 V	1.67 A	80 W
36 V	0.84 A	36 V	0.84 A	60 W
36 V	1.12 A	36 V	1.12 A	80 W

INPUT			
18 - 32 V	40 - 60 V	88 - 150 V	175 - 300 V
PM80 24/24-24			
	PM80 48/24-24	PM80 110/24-24	PM80 220/24-24
PM80 24/36-36			
	PM80 48/36-36	PM80 110/36-36	PM80 220/36-36

How to read our product code: Example PM80 48/24-24
 PM80 = Family code, 48 = input voltage code 48, 24-24 = Two outputs with nom. voltage 24 V

DC INPUTS

NOMINAL INPUTS	INPUT RANGE	CODE
24 Vd.c.	18 - 32 V	24
48 Vd.c.	40 - 60 V	48
110, 127 Vd.c.	88 - 150 V	110
220, 250 Vd.c.	175 - 270V	220

Input voltages meeting train standard EN 50155/IEC 60571, can be made on demand.

FEATURES

LABEL	VALUE
Design topology	Flyback
Switching frequency	typ. 45 kHz
Emission / Immunity	See page 4
Safety EN IEC 60950	Class I
Max. accepted input ripple1 50-400 Hz	2 % of nominal voltage
Input power at no load	< 5 W
Inrush current limit	No
Reverse input voltage protection	
24, 48 input code	Parallel diode
110, 220 input code	Series diode
Dimensions (D x W x H)	157 x 106 x 48 mm
Weight	0.65 kg
Power connector	0,25 - 2,5 mm ²

1. Higher ripple affects the input, contact factory

HOW TO CONNECT THE OUTPUTS

Use the supplied jumpers shown below

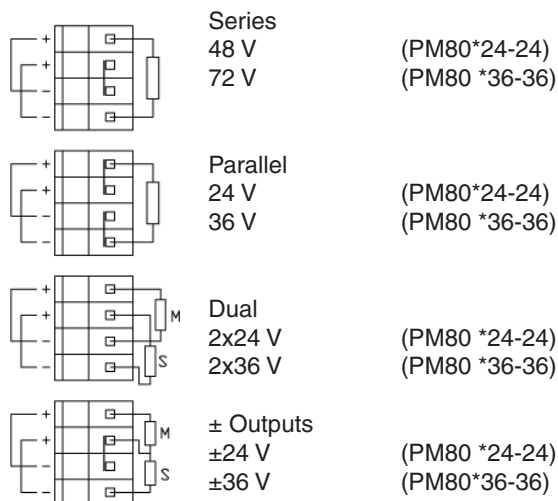

*= Input voltage code. M = Master output U1. S= Slave output U2.
Figure 1. Jumper position on PM80 connector (Series & Parallel)

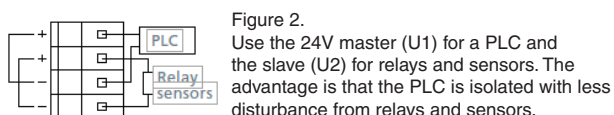

OUTPUT DATA

LABEL	
Source regulation	0.2%
Load regulation parallel outputs	0.2%
Load regulation with series connected outputs 10-100% load	0.2%
Load regulation on U1	See figure 2
Load regulation on U2	Typ. <3 ms
Transient recovery time for 10 to 90% load step to within 3% of nominal output voltage.	Typ. 1 mVRMS
Output ripple (45 kHz) ²	Typ. 1 mVRMS
Input ripple attenuation to output (50 to 400 Hz)	150:1
Emission / Immunity	See page 4
Temperature coefficient	0.02%/°C
Output adjustment range adjustable with a 15 turn potentiometer	
PM80*24-24	21.6 - 26.4 V
PM80*36-36	32.4 - 39.6 V
Current limit, fold-back	See figure 4
Remote sense	No
Soft start	No
Start-up time	1 s
Hold-up time, contact factory	2 - 25 ms
Efficiency ³	83 - 85 %
Operating temperature range at 100% load ⁴ .	-25 to +55 °C
Storage temperature range	-40 to +85 °C

- The output ripple might increase to 0.5% RMS of V_{out} , when EN IEC 61000-4-3, 10 V/m test is applied.
- Lowest efficiency measured within the whole input voltage range at 100% load.
- 40 °C on request.

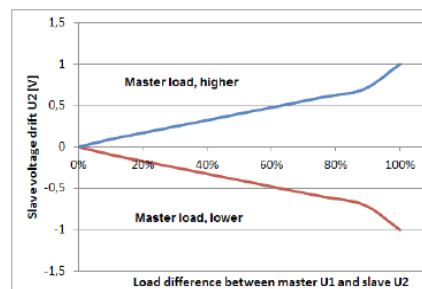

Figure 3. Voltage different between U1 & U2 depending on load difference on PM80*/24-24.

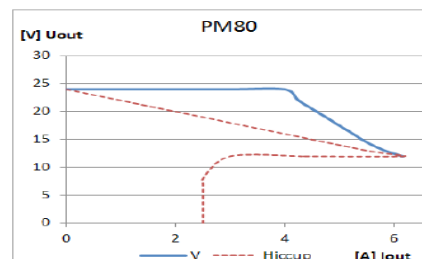
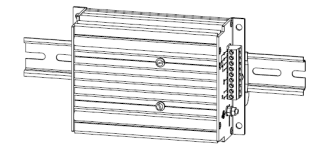
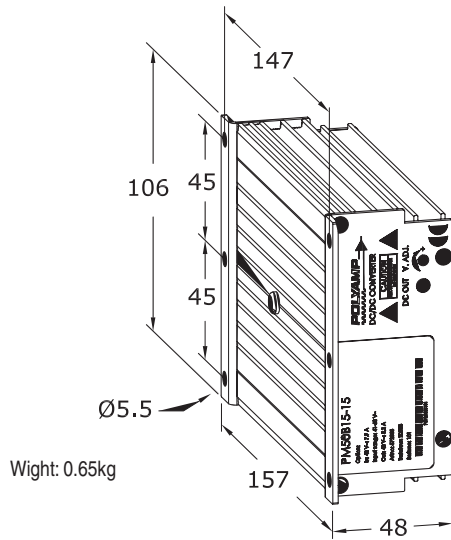
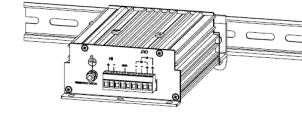

Figure 4. Current limit characteristic for PM80*/24-24 with outputs connected in parallel.

MECHANICAL DRAWING



PM50/80 Wall or DIN-rail mounted (standard)



PM50/80 DIN-rail mounted L60-1 (option)

Figure 5. Dimensions

OUTPUT VOLTAGE/POWER CHARACTERISTICS

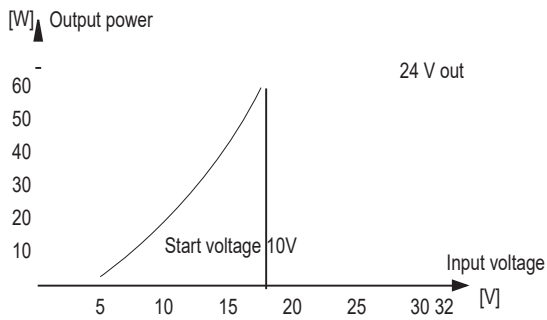

Figure 6. Output power PM80 24/24-24

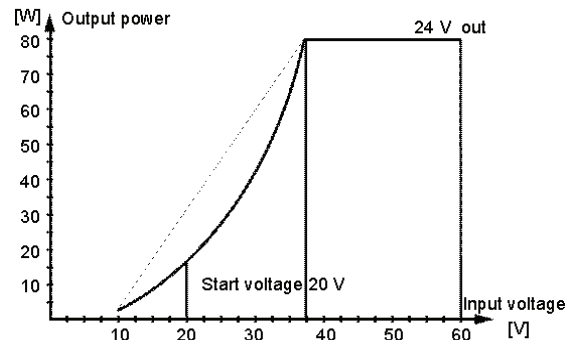

Figure 7. Output power PM80 48/24-24

The PM80 series have no low input voltage lock-out, which stops the converter. The output power is instead automatically derated, see figures 6 to 9. Example: PM80 24/24-24, figure 6, has start voltage at 10 V and can supply 20 W output power at 10 V input.

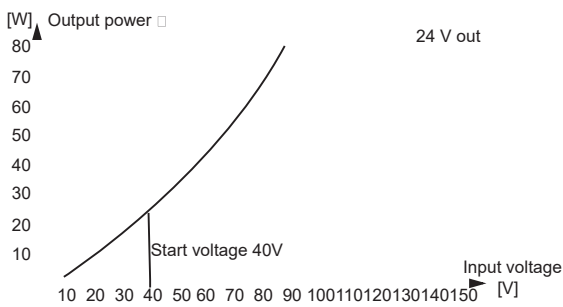

Figure 8. Output power PM80 110/24-24

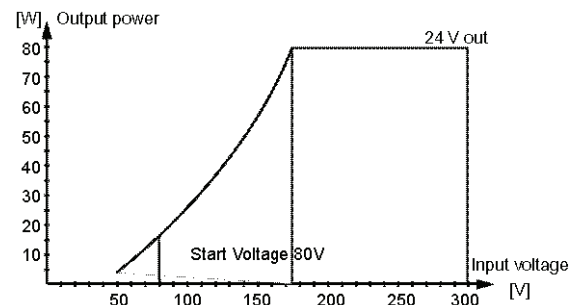

Figure 9. Output power PM80 220/24-24

CE MARK

PM80 meets the requirements defined by CE mark as apparatus.

PM80 meets requirements of EMC directive and low voltage directive (LVD) and RoHS II directive.

The PM80 family is in respect to EMC, a stand alone unit that can also be installed in any other environment by a professional installer.

Please note that product standards can demand different levels or other basic standard tests. We test according to levels below. For higher levels or other tests, contact factory

SAFETY STANDARD EN/IEC 60950

Isolation testable levels	Test voltage
Input / Output: Input code 24, 48	2 kVd.c.
Input code 110, 220	2.5 kVa.c. / 4 kVd.c.
Input / Case: Input code 24, 48	2 kVd.c.
Input code 110, 220	2.5 kVa.c. / 4 kVd.c.
Output / Case all outputs	1 kVd.c.
Between U1 / U2	500 kVd.c.

EMC

EMC standards	EMC Performance		Remarks
Emission standards	EN IEC 61000-6-3		Commercial and light-industrial environments
	Input	Output	
EN 55016 CISPR 16 (0.15-30 MHz)	OK	OK	opt.EN 55022 level B
EN 55016 CISPR 16 (30-1000 MHz)	OK		Enclosure test
Immunity standards	EN IEC 61000-6-2		Industrial environments
EN IEC 61000-4-2	8 kV / 8 kV		Contact / air, Enclosure test
EN IEC 61000-4-3	10 V/m AM-Modulated		Output ripple can increase to 0.5% of Vout Enclosure test
EN IEC 61000-4-4	± 4 kV	± 4 kV	
EN IEC 61000-4-5, Input code A, B	± 0.5 kV / ± 1 kV	± 0.5 kV / ± 1 kV	Line-line 2 Ω / Line-case 12 Ω
EN IEC 61000-4-5, Input code C, D	± 1 kV / ± 2 kV	± 0.5 kV / ± 1 kV	Line-line 2 Ω / Line-case 12 Ω
EN 50121-3-2, IEC 62236-3-2	± 1 kV / ± 2 kV	± 1 kV / ± 2 kV	Line-line 42 Ω / Line-case 42 Ω
EN IEC 61000-4-6	10 V _{RMS}	10 V _{RMS}	AM-Modulated
EN IEC 61000-4-8	Not sensitive		Enclosure test
EN IEC 61000-4-10	Not sensitive		Enclosure test

1. Higher level 2 kV / 4 kV with external filters, contact factory.

We use the EMC product standard "Low voltage power supplies DC output" EN 61204-3 as base for measurement principles. The Immunity EMC levels are elevated in order to comply to EN 50121-3-2 (IEC 62236-3-2) Railway application: Rolling stock – Apparatus, and EN 50121-4 (IEC 62236-4)

Railway application: Signaling and telecommunication apparatus. Also to meet relevant parts of IEC 61000-6-5 Generic Standards – Immunity for power stations and substation environments.