



 II 2 (1) GD

## Earth-Rite PLUS Static Grounding System

Model: ER11 Oct 09  
Installation & Operating Instructions

[www.newson-gale.com](http://www.newson-gale.com)

# Earth-Rite II

## Static Earth Monitoring System

System using an Exd IIC Control Unit  
Terminology used in this manual

### Earth & Ground

The words "Earth" and "Ground" have the same meaning when used within this manual.

The term "Ground" and "Grounding" are used in US electrical engineering to represent electrical equipment that is securely bonded to the ground (i.e., that on which we stand) for safety reasons. In the UK the equivalent terms are "Earth" and "Earthing".

### Tri-Mode and Single Mode

The **Earth-Rite II RTR** system operates using "Tri-Mode" technology which uses the electrical capacitance of the road tanker to ensure the presence of an affective Static Earth Point to which the road tanker is connected. It also monitors that the clamp is connected to a road tanker rather than directly to earthed structures or isolated items of metal. Once permissive, the system continues to monitor the resistive loop circuit from tanker to the Static Earth Point.

The **Earth-Rite II PLUS** system operates using "Single Mode" technology which monitors the complete resistive loop from plant item to the designated site Static Earth Point.

### Core and Conductor

The words "core" and "conductor" are used within the context of this manual to refer to a single insulated metal wire which can be an individual entity or assembled together as a group within a multi-core cable.

### Installation

All cables entering the monitoring unit must be connected through approved cable glands in accordance with EN 60079-14 .

The glands should be fitted in such a way as to maintain the ingress protection rating of the enclosure.

The system should be connected as per the enclosed installation drawings.

The Earth-Rite II system can be powered from a range of supply voltages dependent upon the model.

The unit should be protected using a 2A fast blow fuse mounted in the distribution board / fuse box.

The monitoring unit should be mounted, with the indicator window facing away from direct sunlight, at a convenient location, visible to the operator.

For operation in Tri-Mode the Junction Box should be mounted no more than 3m (cable distance) from the control unit.

Note: It is recommended that the transfer or mixing operation is interlocked with the contacts of the Earth-Rite II unit. This will ensure that the operation is stopped if the earth connection is inadvertently lost.

### Tri-Mode and Single Mode

**RTR System:** If the **Earth-Rite II** has been supplied as a **Tri-Mode** system (capacitive / resistive version), it is intended for use with Road Tankers. It is set to show permissive only when the system detects the presence of a road tanker and when the connection to earth is less than 10 Ohms nominal resistance. Until this condition is achieved, the system remains non-permissive.

A device known as the RTR Tester is available to allow the Earth-Rite II RTR to switch to permissive for test purposes when a road tanker is not present.

**PLUS System:** If the **Earth-Rite II** has been supplied as a **Single-Mode** system (resistive only version), it is intended for use with any conductive metal item such as a drum, mixing vessel, rail tanker etc. It is set to show permissive only when the system detects that the connection to the plant item, and to earth, is less than 10 Ohms nominal resistance. Until this condition is achieved, the system remains non-permissive.

### Other Approvals

#### Functional Safety

The Earth-Rite II has been given a SIL (Safety Integrity Level) rating of 2.

#### Electromagnetic Compatibility

The Earth-Rite II has been tested and shown conformity to European Directive 2004/108/EC, and FCC Part 15 Emissions.

Conformity has been proven to BS EN 61000-6-3 and BS EN 61000-6-2.

### Certification Label Detail

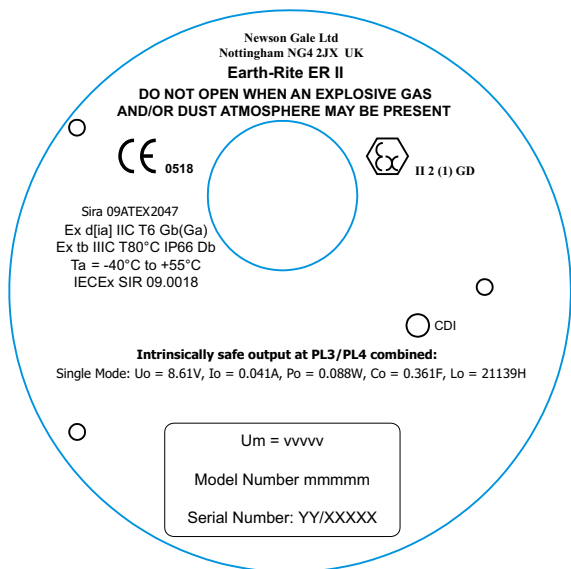

This label is fitted behind the window of the Earth-Rite II Exd enclosure

# Customer Supplied Cable Specification

## Recommended Specification

**Cable from ERII Control Unit to ERII Junction Box**  
1.0mm<sup>2</sup> 2 core Cable with blue sheath or identifier (IS Circuit).

**Cable from ERII Unit to Pump Starter**  
AC: 1.0mm<sup>2</sup> 2 core cable + Earth

**Cable from Supply to the ERII Unit**  
AC: 1.0mm<sup>2</sup> 2 core cable + Earth

**Cables from ERII Unit to Site Static Earthing Point**  
4mm<sup>2</sup> single core cable with green sheath.

**Cable from ERII Unit to optional Mode Selector Key Switch**  
1.0mm<sup>2</sup> 2 core cable (IS circuit)

**NOTE:** Cables must be secured close to the enclosure in order to prevent them being accidentally pulled out.

## Cable Glands

Where the monitoring unit is mounted within an area requiring IIC apparatus, the following cable entry method is permitted: Flameproof cable entry device incorporating a compound filled seal around the individual cores or other equivalent sealing arrangement. eg. an approved Ex d Compound-Filled Barrier Cable Gland.

Where the monitoring unit is mounted outside an area requiring IIC apparatus, a suitable flameproof cable entry device with a sealing ring is permitted. eg. an approved Ex d Cable Gland.

Please refer to EN 60079-14 for further information.

**IF YOU ARE IN ANY DOUBT REGARDING THE INSTALLATION THEN PLEASE CONTACT NEWSON GALE, OR THEIR APPROVED DISTRIBUTOR, WITHOUT DELAY.**

## Earth-Rite II PLUS (Single-Mode) Operation

In the normal quiescent state, with clamp stowed on the insulated pin, the Red Negative Ground Connection LED will show.

Attach the earthing clamp onto the item of conductive plant at a suitable position and ensure that both of the pointed contacts are positively located.

If the connection is healthy then the Green Positive Ground Connection LEDs will flash and the interlock contacts will close.

The product transfer / mixing operation can now take place.

If the earth connection is broken during the transfer / mixing operation then the Red Negative Ground Connection LED will show and the interlock contacts will open.

On completion the earthing clamp should be removed from the plant item and stowed on the insulated pin on the front of the junction box. The Red Negative Ground Connection LED will show.

**Note** - The earthing clamp should be fitted prior to any other operation as per the recommendations of CLC/TR: 50404, NFPA 77 and API RP 2003.

## Exd Monitoring Unit

Copper-free Cast-aluminium Enclosure

## Installation & Maintenance Instructions

The lid of the enclosure is removed by rotating it in an anti-clockwise direction. A pair of tools, which locate in the two holes in the lid, can be provided to assist in this operation.

After installation of wiring, secure the cover to the body making sure it is fully tightened.

Periodically check exterior of enclosure for damage or deterioration.

**IF YOU HAVE ANY QUERIES REGARDING THE ABOVE POINTS THEN PLEASE CONTACT NEWSON GALE, OR THEIR APPROVED DISTRIBUTOR, WITHOUT DELAY.**

## Troubleshooting at the time of Installation – Earth-Rite II PLUS - Single Mode System

Before contacting Newson Gale please check the following points:-

### Symptom: Red and/or Green LEDs are NOT showing

**Check** that the system is installed in accordance with the supplied manual.

**Check** that there is power to the monitoring unit, and that it is the correct voltage.

**Caution - Ensure all Health & Safety precautions are taken during the above procedures.**

**Symptom: System is NOT switching to permissive state when clamp is fitted to road tanker (RED LED continues to show).**

**Check** that the system is installed in accordance with the supplied manual.

**Check** That the grounding clamp is in good condition: that the contacts are level with each other, sharp and not loose.

**Caution - Ensure all Health & Safety precautions are taken during the above procedures.**

**If the system still does not switch to permissive state when clamp is fitted to the plant item please contact Newson Gale and confirm the following:-**

Serial number \_\_\_\_\_

Company which ordered the system

\_\_\_\_\_

Date of order \_\_\_\_\_

Any other information

\_\_\_\_\_

# Component Identification – **EARTH-RITE II SYSTEM**

Earth-Rite II RTR MONITORING PCB

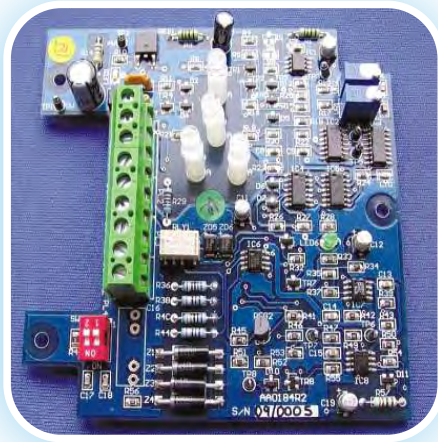

Earth-Rite II PLUS MONITORING PCB

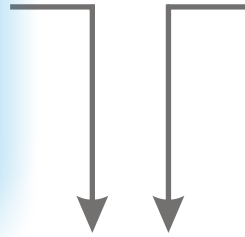
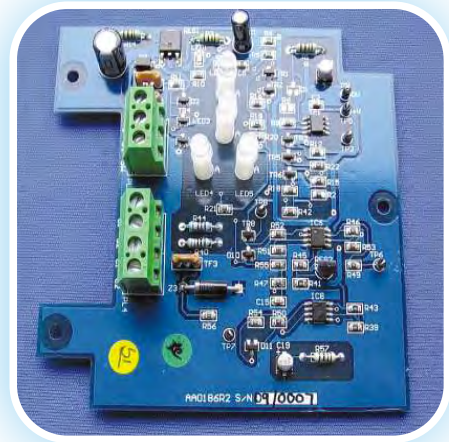

VAC - FORM INSULATING COVER



AC POWER SUPPLY



# Earth-Rite II Cable Connections AC

DESIGNATED  
ZONE 1 / 21 or  
2 / 22 AREA

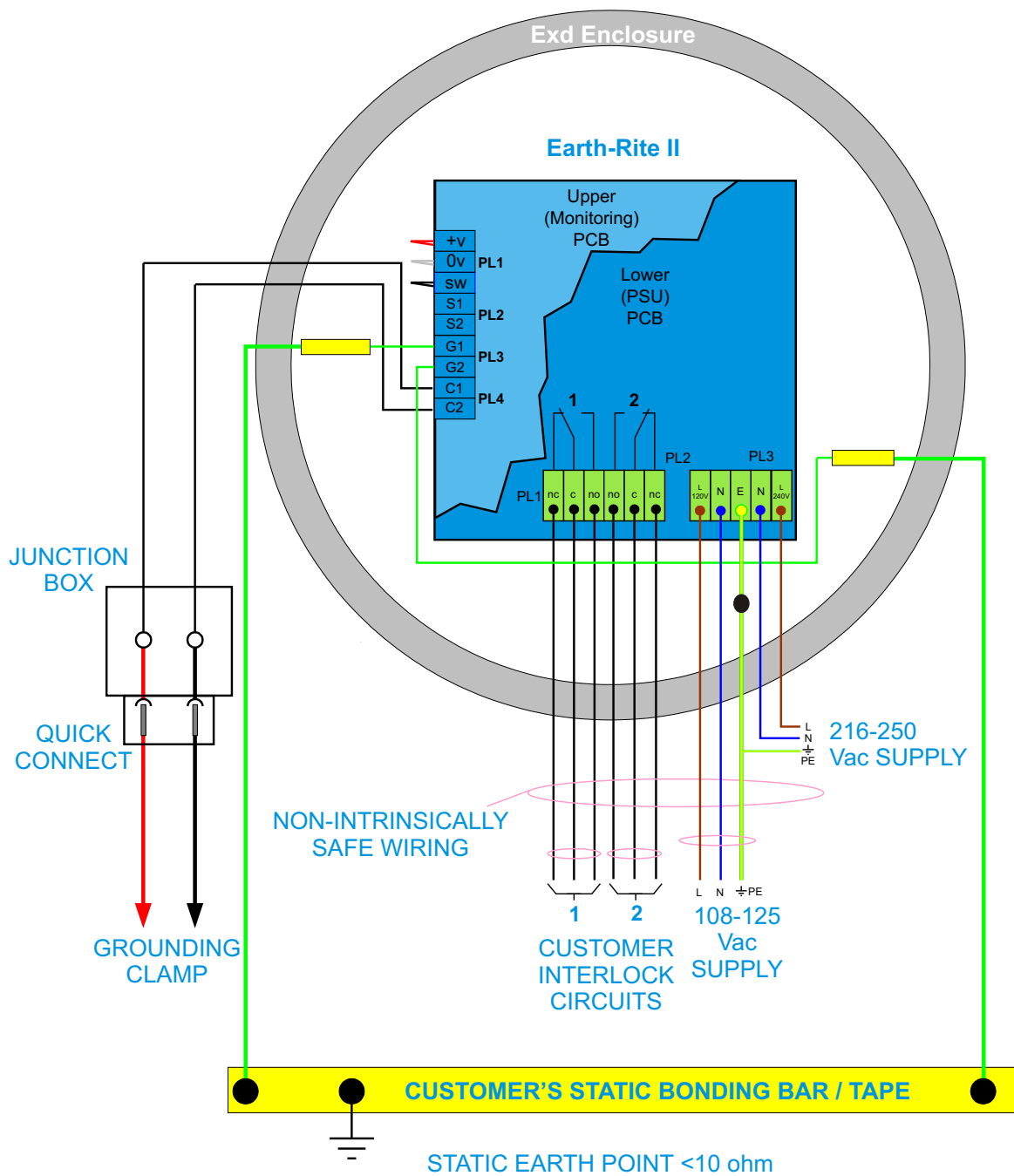

## PCB Connections Power Supply PCB

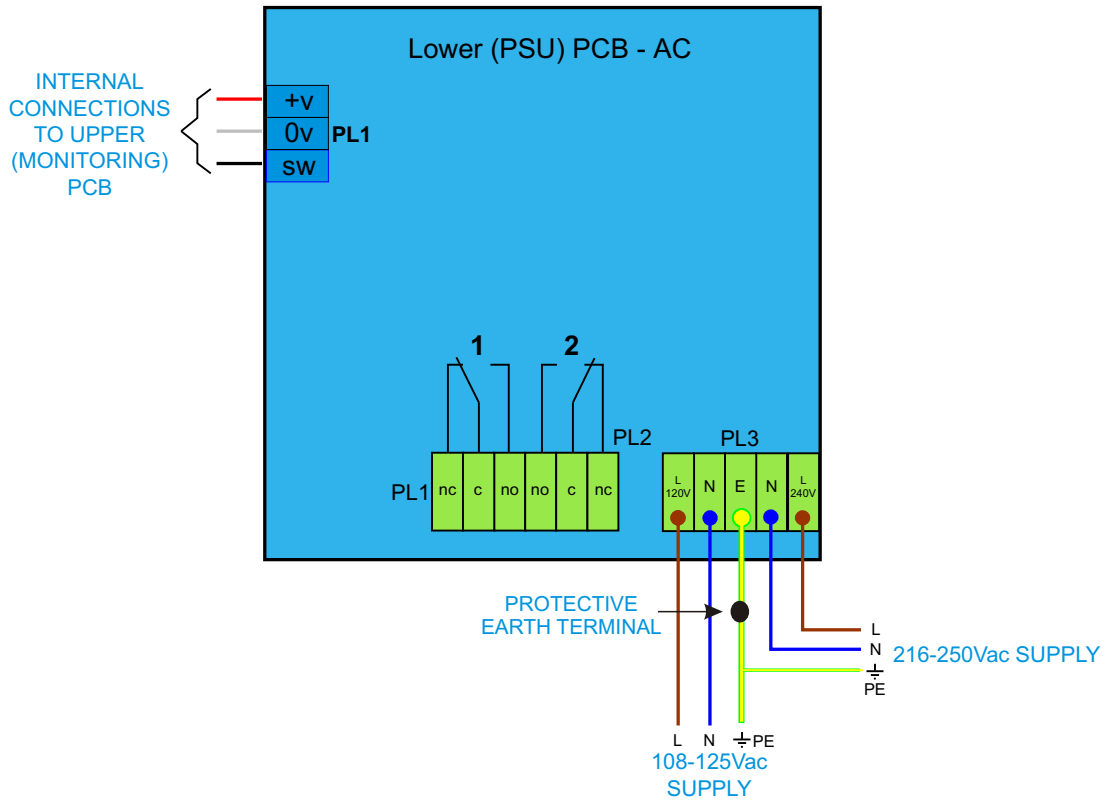

## PCB Connections Monitoring PCB

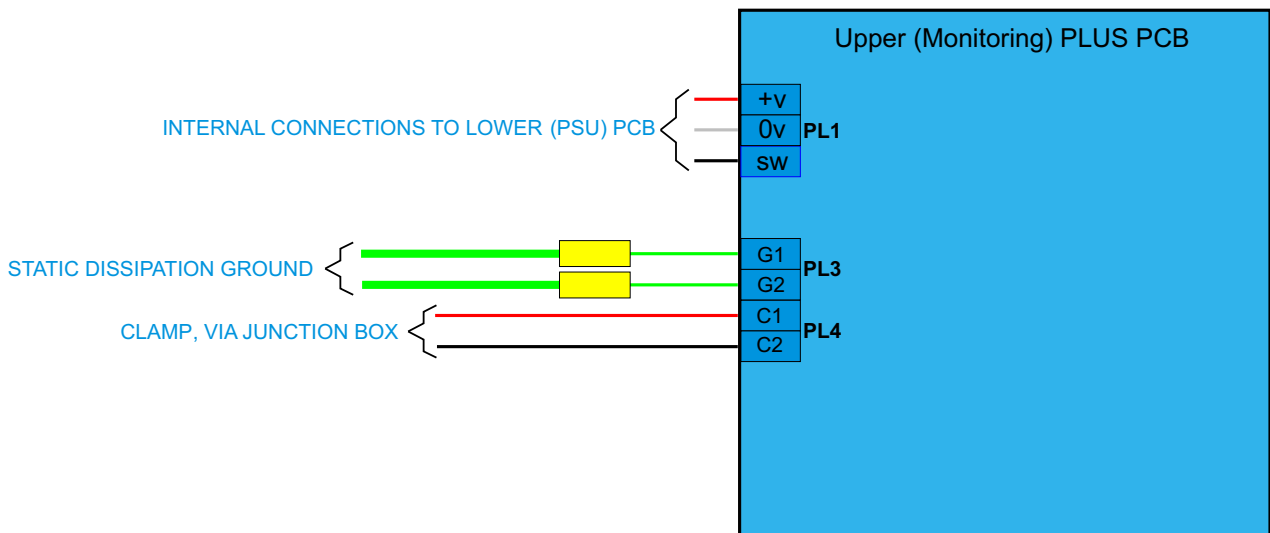

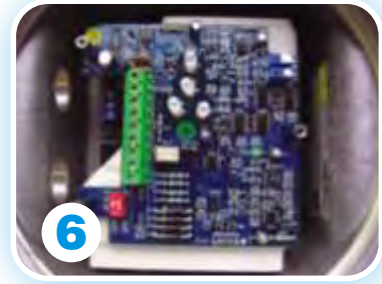
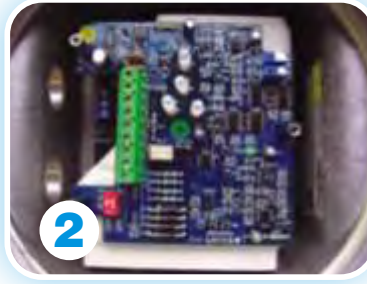

## Internal Component Assembly

Always observe precautions against damage to the PCB's from electrostatic discharge.

1. Remove the lid of the enclosure and remove the blue approval label. This can be achieved by unscrewing the left-hand screws 4 revolutions anti-clockwise and removing the right-hand screw completely.
2. Disconnect the three wires from the terminal block. Remove the monitoring PCB by unscrewing the three hexagonal metal pillars. Place the PCB in the anti-static bag provided and keep it safe.
3. Remove the vac-form insulating cover.
4. Install the various cables into the enclosure using suitable glands. Make the connections to the Power Supply PCB.
5. Replace the vac-form insulating cover.
6. Replace the monitoring PCB and secure using the three hexagonal metal pillars. Make the connections into the Terminal block.
7. Replace the blue approval label and secure using the screws provided. Replace the lid of the enclosure securely.

## Protective Earth Terminal Location

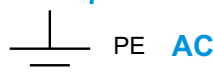

# Earth-Rite ERII Dimensions

**Earth-Rite II Exd Controller**

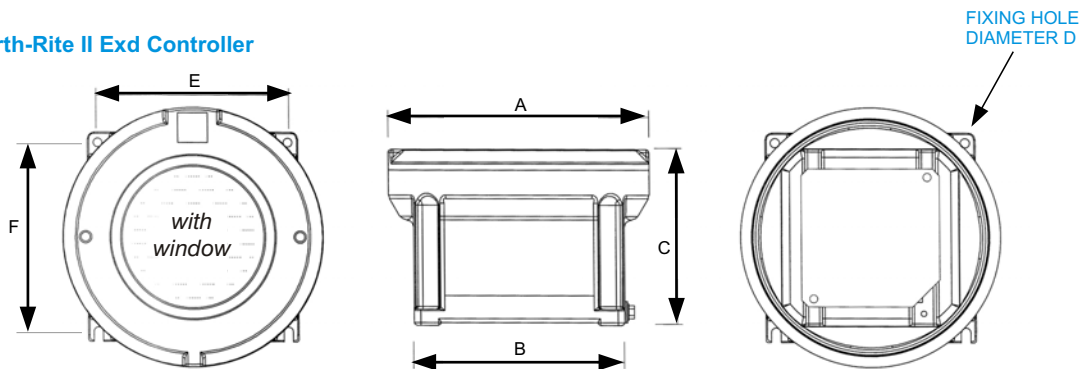

**Junction Box**

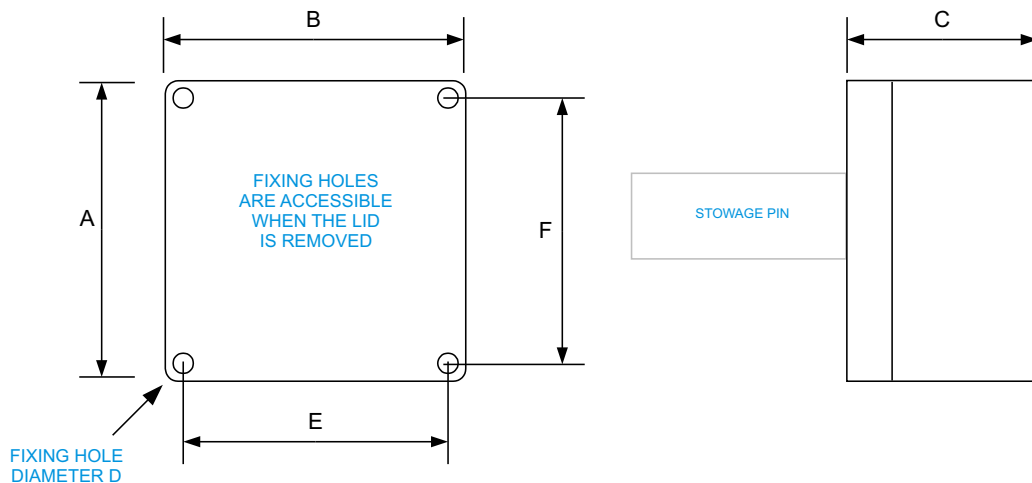

PRODUCT DESCRIPTION	MAIN DIMENSIONS			FIXING DIMENSIONS		
	A mm	B mm	C mm	D mm	E mm	F mm
Junction Box with 3/4" Stowage Pin	75	80	57	4.5	68	45
Exd Earth-Rite II Controller	192	155	132	7	140	140



## Earth-Rite II - AC Technical Specification

### Monitoring Unit

Power supply	230/240V 50Hz system (Supply voltage range: 216V to 250V) 110/120V 50Hz system (Supply voltage range: 108V to 125V)
Power rating	10 watt
Ambient temperature range	-40°C to +55°C
Ingress protection	IP66
Weight	4.5 kgs (nett)
Construction	Copper-free cast-alloy
Certification	Ex d[jia] IIC T6 Gb(Ga) Ex tb IIIC T80°C IP65 Db Ta = -40°C to +55°C

Monitoring circuit	Intrinsically safe
Operational series ground resistance	</= 10 Ohm
Output Relay contact rating	2 off voltage free change-over switch contacts, 250Vac, 5A, 500VA max resistive
Cable entries	7 x M20 (2 x plugged)

### Junction box/stowage point

Enclosure	GRP with carbon loading
Terminals	2 x 2.5mm <sup>2</sup> conductor capacity
Stowage device	Insulated 20mm Ø pin
Cable entries	1 x 20mm
Clamp Cable Connection	Quick Connect

### Earthing clamp

Clamp design	2 pole with tungsten carbide contacts
Body	Stainless steel

### Spiral Cable

Cover	Blue Cen-Stat Hytrel sheath (Static dissipative, chemical & abrasion resistant)
Conductors	2 x 1.00mm <sup>2</sup> copper
Length	10 metres extended, 1 metre unextended (other options available)

NB: In line with our policy of continual product development, we reserve the right to alter specifications at any time.

# Operation

Note: The Earthing Clamp should be fitted prior to any other operation.

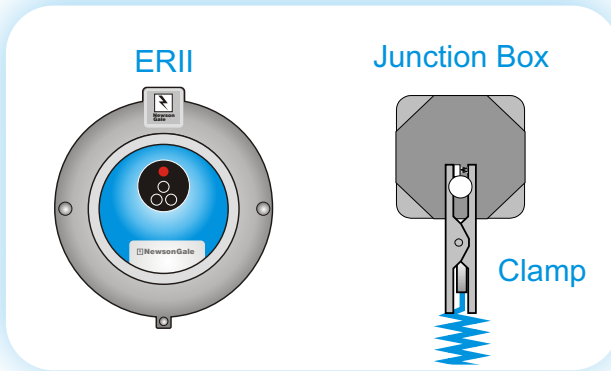

**A.** In the normal "rest" state, with the Earthing Clamp stowed on the insulated pin, the **Red** Negative Earth Condition LED will be showing.



**B.** Attach the Grounding Clamp onto the Plant Item at a suitable point and ensure that the pointed contacts are positively located.

If the connection to the Plant Item and Earth is good, then the **Green** Positive Earth Condition LEDs will flash and the interlock contacts will close.

The process operation can now take place.



**C.** If the connection between the Plant Item and ground is broken during the transfer operation, then the **Red** Negative Earth Condition LED will show and the interlock contacts will open.

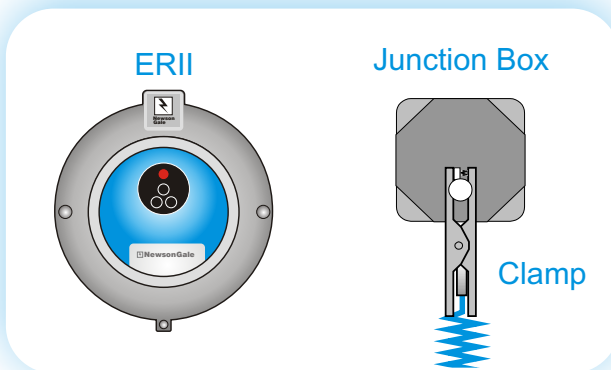

**D.** On completion the Grounding Clamp should be removed from the Plant Item and stowed on the insulated pin on the front of the junction box. The **Red** Negative Earth Condition LED will show.

## User instructions in compliance with IEC 60079-0:2007 clause 30

The following instructions apply to the **Earth-Rite II Earth Monitoring Unit, Ex d[ia]**, covered by certificate numbers **IECEX SIR 09.0018** and **Sira 09ATEX2047**.

### Instructions for safe selection, installation, use, maintenance and repair

The equipment may be used in zones 1, 2, 21 and 22 with flammable gases and dusts.

The equipment may be used in the presence of flammable gases and vapours with apparatus groups IIC or IIB or IIA and with temperature classes T1 or T2 or T3 or T4 or T5 or T6.

The equipment may be used in the presence of flammable dusts, powders and flyings, conductive or non-conductive, the only limitation being the maximum external surface temperature of 80°C.

The equipment is certified for use in ambient temperatures in the range of -40°C to +55°C and should not be used outside this range.

The equipment is to be installed by suitably trained personnel in accordance with the applicable code of practice (typically IEC/EN 60079-14)

Protective insulated plugs are fitted to help prevent the supply cables from being connected to the wrong terminals. Check which supply voltage is required and remove the plug from that terminal only.

No user adjustment is required.

Regular periodic inspection of the equipment should be performed by suitably trained personnel in accordance with the applicable code of practice (typically IEC/EN 60079-17) to ensure it is maintained in a satisfactory condition.

The equipment is not intended to be repaired by the user. Repair of the equipment is to be carried out by the manufacturer, or their approved agents, in accordance with the applicable code of practice.

The equipment contains no user-replaceable parts.

### Certification Label Detail

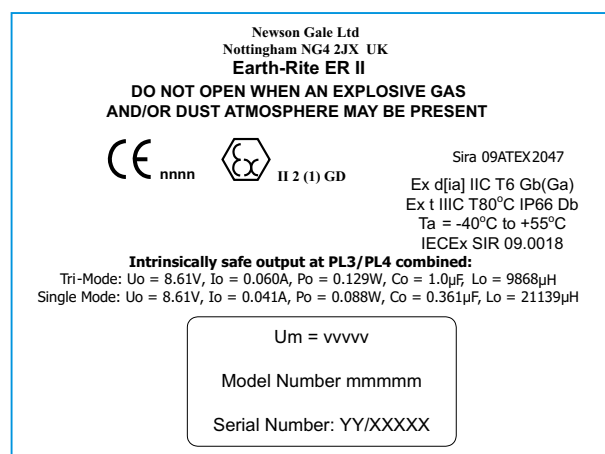

### Verification of the Static Earthing Point

The system monitors the static dissipation path, from the object to which the Static Earthing Clamp or lead is connected to, as far as the Static Earthing Point.

It is the responsibility of the end user to provide the Static Earthing Point and ensure that it is suitable for dissipating electrostatic charges. Reference to ATEX 95, ATEX 137, EN 60079-14, CLC/TR 50404, or other equivalent international standard, will give guidance on the installation of a suitable Static Earthing Point.

The above does not apply to any system used to monitor a bond connection only.

**IF YOU HAVE ANY QUERIES REGARDING THE ABOVE POINTS THEN PLEASE CONTACT NEWSON GALE WITHOUT DELAY.**